



US 20140071030A1

(19) **United States**  
(12) **Patent Application Publication**  
Lee

(10) **Pub. No.: US 2014/0071030 A1**  
(43) **Pub. Date: Mar. 13, 2014**

(54) **PIXEL ARRANGEMENT STRUCTURE FOR ORGANIC LIGHT EMITTING DIODE DISPLAY**

**Publication Classification**

(71) Applicant: **SAMSUNG DISPLAY CO., LTD.**,  
Yongin-City (KR)

(51) **Int. Cl.**  
**G09G 3/32** (2006.01)

(72) Inventor: **Sang-Shin Lee**, Yongin-City (KR)

(52) **U.S. Cl.**  
CPC ..... **G09G 3/3208** (2013.01)  
USPC ..... **345/82**

(73) Assignee: **SAMSUNG DISPLAY CO., LTD.**,  
Yongin-City (KR)

(21) Appl. No.: **13/872,018**

(57) **ABSTRACT**

(22) Filed: **Apr. 26, 2013**

A pixel arrangement structure of an organic light emitting diode (OLED) display is provided. The pixel arrangement structure includes: a first pixel having a center coinciding with a center of a virtual square; a second pixel separated from the first pixel and having a center at a first vertex of the virtual square; and a third pixel separated from the first pixel and having a center at a second vertex neighboring the first vertex of the virtual square. The first pixel, the second pixel, and the third pixel have polygonal shapes.

**Related U.S. Application Data**

(63) Continuation-in-part of application No. 13/614,197, filed on Sep. 13, 2012.

**Foreign Application Priority Data**

Mar. 6, 2013 (KR) ..... 10-2012-0022967  
Apr. 23, 2013 (KR) ..... 10-2013-0044993

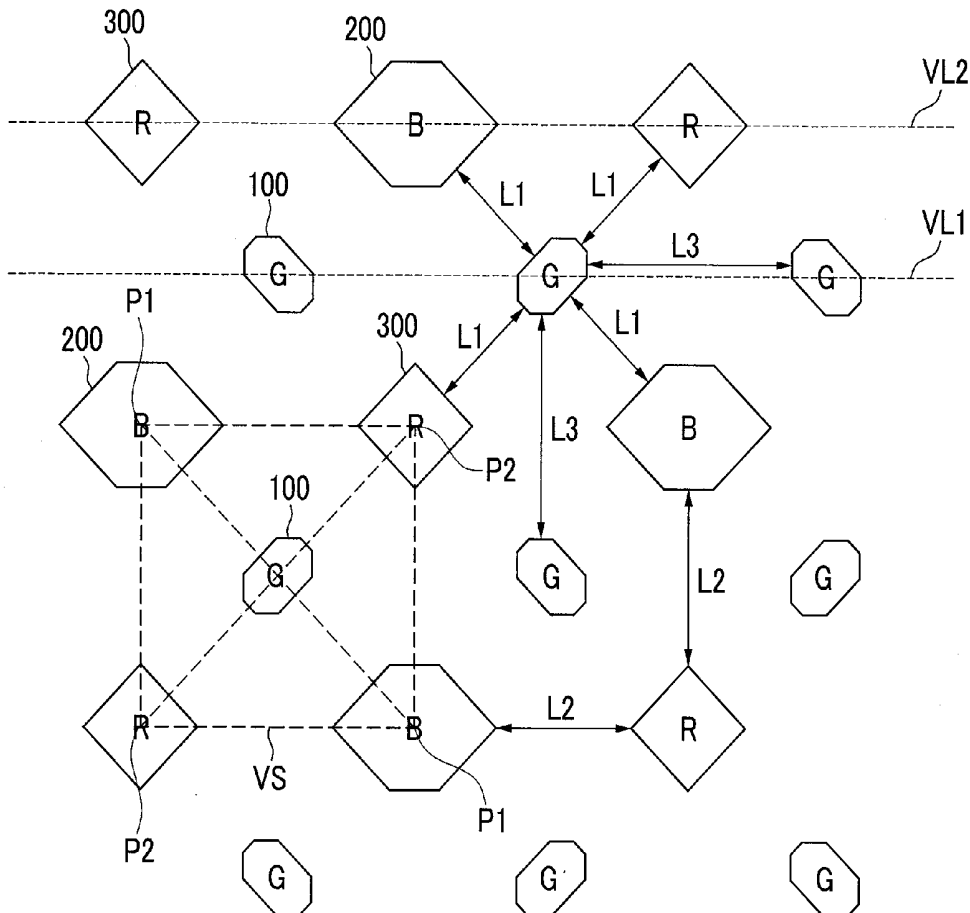

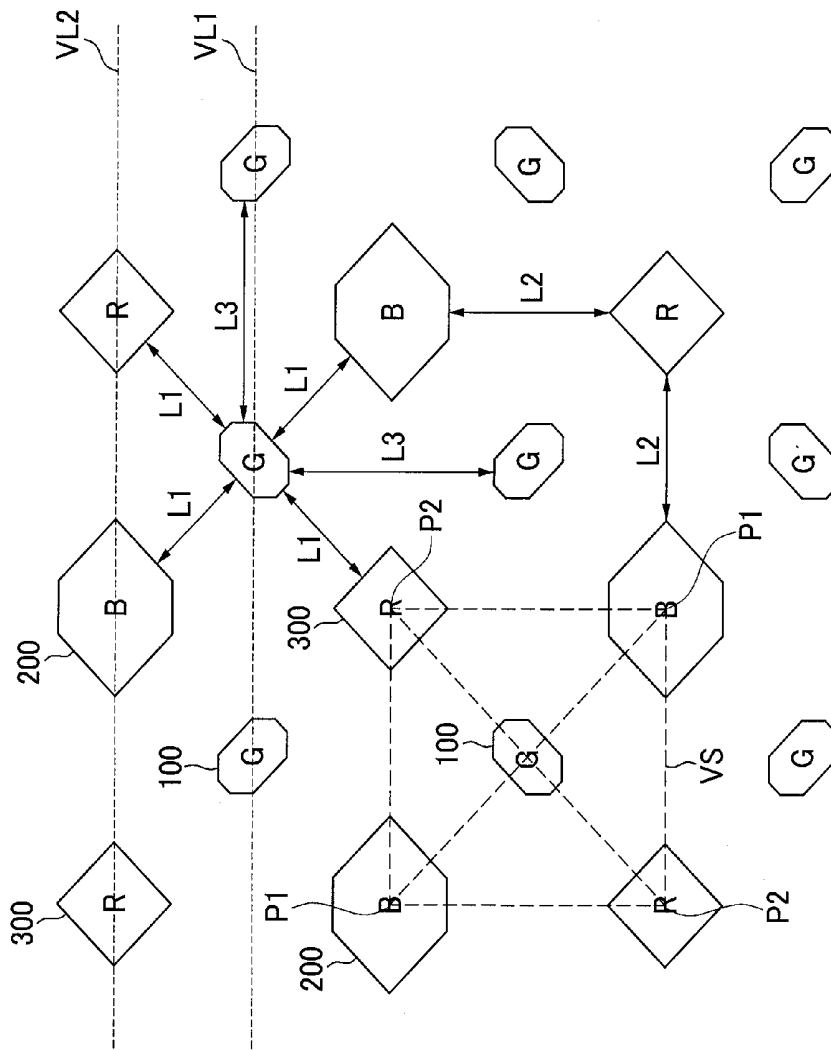

**PIXEL ARRANGEMENT STRUCTURE FOR  
ORGANIC LIGHT EMITTING DIODE  
DISPLAY**

**CROSS-REFERENCE TO RELATED  
APPLICATION**

[0001] This application is a continuation in part of U.S. application Ser. No. 13/614,197, filed Sep. 13, 2012, which claims priority to and the benefit of Korean Patent Application No. 10-2012-0022967, filed in the Korean Intellectual Property Office on Mar. 6, 2012. This application also claims priority to and the benefit of Korean Patent Application No. 10-2013-0044993, filed in the Korean Intellectual Property Office on Apr. 23, 2013. The entire contents of all of these are incorporated herein by reference.

**BACKGROUND**

[0002] 1. Field

[0003] Aspects of embodiments of the present invention relate generally to a pixel arrangement structure for an organic light emitting diode (OLED) display.

[0004] 2. Description of the Related Art

[0005] A display device is a device that displays an image. Recently, an OLED display has been drawing attention.

[0006] The OLED display has a self-luminous characteristic. Because the OLED display does not need a separate light source, unlike a liquid crystal display, it can have a relatively smaller thickness and weight than liquid crystal displays. In addition, the OLED display exhibits high-quality characteristics such as low power consumption, high luminance, high response speed, etc.

[0007] In general, the OLED display includes a plurality of pixels for emitting light of different colors. The plurality of pixels emit light to display an image.

[0008] Here, the pixel refers to a minimum unit for displaying the images. For instance, there may be a gate line, a data line, and a power line such as a driving power line to drive each pixel. In addition, there may be an insulation layer such as a pixel definition layer to define an area and a shape of each pixel. Further, each pixel may be positioned between its neighboring pixels.

[0009] An organic emission layer included in the pixel of an OLED display may be deposited and formed by using a mask such as a fine metal mask (FMM). When reducing a gap between the neighboring pixels to obtain a high aperture ratio of the pixels, deposition reliability may be deteriorated. On the other hand, when increasing the gap between the pixels to improve the deposition reliability, the aperture ratio of the pixels may be deteriorated.

[0010] The above information disclosed in this Background section is only for enhancement of understanding of the background of the invention and therefore it may contain information that does not form the prior art that is already known in this country to a person of ordinary skill in the art.

**SUMMARY**

[0011] Aspects of embodiments of the present invention relate generally to a pixel arrangement structure for an OLED display. More particularly, aspects of embodiments of the present invention relate to a pixel arrangement structure of an OLED display that displays an image by emitting light through a plurality of pixels.

[0012] An exemplary embodiment of the present invention provides a pixel arrangement structure for an OLED display having an improved aperture ratio of each of the pixels while efficiently setting up gaps between the pixels.

[0013] According to an exemplary embodiment of the present invention, a pixel arrangement structure of an organic light emitting diode (OLED) display is provided. The pixel arrangement structure includes: a first pixel having a center coinciding with a center of a virtual square; a second pixel separated from the first pixel and having a center at a first vertex of the virtual square; and a third pixel separated from the first pixel and the second pixel, and having a center at a second vertex neighboring the first vertex of the virtual square. The first pixel, the second pixel, and the third pixel have polygonal shapes.

[0014] In one embodiment, the second pixel includes a pair of second pixels, and the second pixels are separated from each other by the first pixel.

[0015] In one embodiment, the third pixel includes a pair of third pixels, and the third pixels are separated from each other by the first pixel.

[0016] In one embodiment, the second pixel includes a pair of second pixels, the third pixel includes a pair of third pixels, and the second pixels and the third pixels enclose the first pixel in the virtual square.

[0017] In one embodiment, each of the second pixels and the third pixels is larger in area than the first pixel.

[0018] In one embodiment, the first pixel has an octagonal shape, and at least one of the second pixel or the third pixel has an octagonal shape.

[0019] In one embodiment, the first pixel has an octagonal shape, and one of the second pixel or the third pixel has a hexagonal shape and an other of the second pixel or the third pixel has a quadrilateral shape.

[0020] In one embodiment, the virtual square includes a pair of virtual squares sharing a common side, the first pixel includes a pair of first pixels having centers respectively coinciding with centers of the virtual squares, and the first pixels have octagonal shapes that are symmetrical to each other.

[0021] In one embodiment, each of the second pixels is larger in area than each of the third pixels.

[0022] In one embodiment, a distance between the first pixel and the second pixels as well as a distance between the first pixel and the third pixels is a same first length.

[0023] In one embodiment, the virtual square includes a pair of virtual squares sharing a common side, the first pixel includes a pair of first pixels having centers respectively coinciding with centers of the virtual squares, a distance between each of the second pixels and the third pixels is a same second length, and a distance between the first pixels is a third length that is longer than the first length and the second length.

[0024] In one embodiment, the first pixel, the second pixel, and the third pixel are configured to emit different color light.

[0025] In one embodiment, the first pixel is configured to emit green light, one of the second pixel or the third pixel is configured to emit blue light, and an other of the second pixel or the third pixel is configured to emit red light.

[0026] According to an exemplary embodiment of the present invention, the pixel arrangement structure of the OLED display improves the aperture ratio of the pixels while efficiently setting up the gaps between the pixels.

## BRIEF DESCRIPTION OF THE DRAWING

[0027] The drawing is a view of a pixel arrangement structure of an OLED display according to an exemplary embodiment of the present invention.

## DETAILED DESCRIPTION

[0028] Several exemplary embodiments according to the present invention are described hereinafter in detail with reference to the accompanying drawing to allow one of ordinary skill in the art to practice the invention without undue experimentation. The present invention can be embodied in several different forms, and is not limited to the exemplary embodiments that are described herein.

[0029] In order to clarify the description of embodiments of the present invention, parts that are not related to the invention may be omitted. In addition, the same elements or equivalents are referred to with the same reference numerals throughout the specification.

[0030] Further, since sizes and thicknesses of constituent members shown in the accompanying drawing may be arbitrarily given for better understanding and ease of description, the present invention is not limited to the illustrated sizes and thicknesses.

[0031] In addition, unless explicitly described to the contrary, the word "comprise" and variations such as "comprises" or "comprising" will be understood to imply the inclusion of stated elements but not the exclusion of any other elements.

[0032] Hereinafter, a pixel arrangement structure (or pixel arrangement) of an OLED display according to an exemplary embodiment will be described with reference to the drawing. The drawing is a view schematically showing a portion of pixels forming an OLED display.

[0033] The drawing shows a pixel arrangement structure of an OLED display according to an exemplary embodiment of the present invention.

[0034] As shown in the drawing, the pixel arrangement structure of the OLED display includes a plurality of first pixels 100, a plurality of second pixels 200, and a plurality of third pixels 300.

[0035] According to one embodiment, the pixel refers to a minimum unit for displaying an image (for example, the minimum addressable unit of the display).

[0036] In one embodiment, among the first pixels 100, the second pixels 200, and the third pixels 300, power lines for driving each of the pixels, such as a gate line, a data line, a driving power line, and the like, are located. In addition, in one embodiment, an insulation layer, such as a pixel defining layer, for defining each of the pixels is disposed.

[0037] Further, in one embodiment, an OLED including an anode, an organic emission layer, and a cathode to correspond to each of the first pixels 100, the second pixels 200, and the third pixels 300 is disposed. These configurations are technologies known in the art and further description thereof is omitted for ease of description. In one embodiment, the shape of each of the pixels is defined by the power lines, the pixel defining layer, the anode, or the like.

[0038] In the pixel arrangement of the drawing, each of the first pixels 100 has a smaller area (e.g., is smaller in area) than neighboring second pixels 200 and third pixels 300, and has a polygon shape. In the drawing, the first pixels 100 have an octagonal shape among the polygon shapes. In other embodiments, the first pixels 100 have one or more of various poly-

gon shapes such as a triangle, a rectangle, a pentagon, a hexagon, a heptagon, and the like. For example, the first pixels 100 that neighbor each other among the plurality of first pixels 100 have hexagon shapes that are symmetrical to each other. In one embodiment, each of the plurality of first pixels 100 has the same hexagonal shape.

[0039] In one embodiment, the first pixels 100 are spaced apart from each other and arranged in rows, such as along a first virtual straight line VL1. In one embodiment, the first pixels 100 emit green light, and include an organic emission layer for emitting green light. In other embodiments, the first pixels 100 include an organic emission layer that emits light of one or more of various colors such as blue, red, or white color for emitting blue light, red light, or white light.

[0040] In the drawing, the second pixels 200 are arranged diagonally with respect to the first pixels 100, namely at first vertices P1 along one diagonal of a virtual square VS having one of the first pixels 100 as a center point (or center) of the virtual square VS. In a similar fashion, in the drawing, the third pixels 300 are arranged diagonally with respect to the first pixels 100, namely at second vertices P2 along the other diagonal of the virtual square VS.

[0041] In the virtual square VS of the drawing, each of the second pixels 200 is separated from the first pixel 100, and is centered at one of the first vertices P1 of the virtual square VS. Each of the second pixels 200 has a larger area than the neighboring first pixel 100 and the neighboring third pixels 300, and has a hexagonal shape. In other embodiments, the second pixels 200 have one or more of various polygonal shapes such as a triangle, a rectangle, a pentagon, a hexagon, a heptagon, and the like.

[0042] In the drawing, the second pixels 200 each have the same hexagonal shape.

[0043] In addition, the second pixels 200 are arranged diagonally and separated from each other by the first pixels 100. In one embodiment, the second pixels 200 emit blue light, and include an organic emission layer for emitting blue light. In other embodiments, the second pixels 200 include an organic emission layer that emits light of one or more of various colors such as red, green, or white for emitting red light, green light, or white light.

[0044] In a similar fashion, in the virtual square VS of the drawing, each of the third pixels 300 is separated from the first pixel 100 and the second pixels 200, and is centered at one of the second vertices P2 neighboring the first vertices P1 of the virtual square VS. Each of the third pixels 300 has a larger area than the neighboring first pixel 100 and a smaller area than the neighboring second pixels 200. The third pixels 300 has a quadrilateral shape among polygon shapes. In other embodiments, the third pixels 300 have one or more of various polygonal shapes such as a triangle, a rectangle, a pentagon, a hexagon, a heptagon, and the like.

[0045] In the drawing, the third pixels 300 each have the same quadrilateral shape. In addition, the third pixels 300 are arranged diagonally and separated from each other by the first pixels 100. In one embodiment, the third pixels 300 emit red light, and include an organic emission layer for emitting red light. In other embodiments, the third pixels 300 include an organic emission layer that emits light of one or more of various colors such as blue, green, or white for emitting blue light, green light, or white light.

[0046] In the drawing, each of the second pixels 200 and the third pixels 300 has a hexagonal shape and a quadrilateral shape, respectively. In another embodiment, each of the sec-

ond pixels **200** and the third pixels **300** respectively has a quadrilateral shape and a hexagonal shape. That is, in this other embodiment, one of the second pixels **200** or the third pixels **300** has a hexagonal shape and the other has a quadrilateral shape.

[0047] In one embodiment, the first pixels **100**, the second pixels **200**, and the third pixels **300** respectively emit green light, blue light, and red light. In other embodiments, the first pixels **100**, the second pixels **200**, and the third pixels **300** emit light of the same color. In still other embodiments, the first pixels **100**, the second pixels **200**, and the third pixels **300** emit light of different colors. In some embodiments, the first pixels **100** emit green light, and one of the second pixels **200** or the third pixels **300** emit blue light while the other emit red light.

[0048] In the drawing, third pixels **300** and the second pixels **200** are spaced apart from each other and alternately arranged in rows, such as along a second virtual straight line VL2. In a similar fashion, in the drawing, the third pixels **300** and the second pixels **200** are spaced apart from each other and alternately arranged in columns. Accordingly, in the drawing, in the virtual square VS, two of the second pixels **200** have their corresponding centers positioned at the first vertices P1 and two of the third pixels **300** have their corresponding centers positioned at the second vertices P2 to enclose a corresponding one of the first pixels **100** in the virtual square VS.

[0049] As described and illustrated in the drawing, the center of each of the second pixels **200** is positioned at one of the first vertices P1 of the virtual square VS. In addition, the center of the corresponding first pixel **100** is the center of the virtual square VS. Further, the center of each of the third pixels **300** is positioned at one of the second vertices P2. Therefore, the plurality of second pixels **200** of which the centers are positioned at the first vertices P1 and the plurality of third pixels **300** of which the centers are positioned at the second vertices P2 respectively enclose one of the first pixels **100** in the virtual square VS.

[0050] Further, and as illustrated in the drawing, the first pixels **100**, the second pixels **200**, and the third pixels **300** have polygon shapes. In the drawing, the distance between one of the first pixels **100** and an adjacent one of the second pixels **200** as well as a distance between one of the first pixels **100** and an adjacent one of the third pixels **300** is the same first length L1. In addition, a distance between one of the second pixels **200** and an adjacent one of the third pixels **300** is a second length L2 that is different from the first length L1. Further, in the drawing, a distance between neighboring first pixels **100** is a third length L3 that is longer than the first length L1 and the second length L2.

[0051] For example, in some embodiments, the first length L1 is between 15  $\mu\text{m}$  (micrometers) and 35  $\mu\text{m}$ , the second length L2 is between 20  $\mu\text{m}$  and 45  $\mu\text{m}$ , and the third length L3 is between 25  $\mu\text{m}$  and 65  $\mu\text{m}$ .

[0052] Therefore, gaps of the first length L1 are formed between adjacent pairs of the first pixels **100** and the second pixels **200**, and between adjacent pairs of the first pixels **100** and the third pixels **300**. In addition, the gaps of the third length L3 that is longer than the first length L1 are formed between the neighboring ones of the first pixels **100**.

[0053] In one embodiment, this results in improved deposition reliability in the deposition process using the fine metal

mask to form the green, blue, and red organic emission layers respectively included in the first pixels **100**, the second pixels **200**, and the third pixels **300**.

[0054] In addition, in one embodiment, the plurality of second pixels **200** and the plurality of third pixels **300** are arranged to enclose the first pixels **100** in the virtual squares VS so that an aperture ratio of each of the first pixels **100**, the second pixels **200**, and the third pixels **300** can be improved. Accordingly, in one embodiment, the manufacturing time and the manufacturing cost of the OLED display is reduced and the display quality of the image of the OLED display is improved.

[0055] Further, in the pixel arrangement structure of the OLED display of the drawing according to an exemplary embodiment of the present invention, the second pixels **200** that emit blue light have the shortest life span among the first pixels **100**, the second pixels **200**, and the third pixels **300**. Accordingly, the second pixels **200** have a larger area than the first pixels **100** and the third pixels **300**, thereby suppressing the deterioration of the life span of the OLED display. That is, in one embodiment, the pixel arrangement structure of the OLED display of the drawing provides improved life span.

[0056] As described above, in the pixel arrangement structure of the OLED display of the drawing according to an exemplary embodiment of the present invention, the first pixels **100**, the second pixels **200**, and the third pixels **300** have simple polygonal shapes such as an octagon, a hexagon, and a quadrangle. In consideration of the deposition process of the organic emission layer, which in one embodiment is a unique manufacturing feature of the OLED display, a center of one of the first pixels **100** is positioned at the center of the virtual square VS, a center of one of the second pixels **200** is positioned at the first vertex P1, and a center of one of the third pixels **300** is positioned at the second vertex P2 to both improve deposition reliability of the organic emission layer in the deposition process using the fine metal mask and improve an aperture of each of the first, second, and third pixels **100**, **200**, and **300**.

[0057] That is, according to an exemplary embodiment of the present invention as illustrated in the drawing, the pixel arrangement structure of the OLED display includes a plurality of first pixels **100** having an octagonal shape, a plurality of second pixels **200** having a hexagonal shape, and a plurality of third pixels **300** having a quadrilateral shape. In one or more embodiments, the shapes and arrangement of the first pixels **100**, the second pixels **200**, and the third pixels **300** improve the deposition reliability of the organic emission layer while also improving the aperture ratio of each of the first pixels **100**, the second pixels **200**, and the third pixels **300**.

[0058] While this invention has been described in connection with what is presently considered to be practical exemplary embodiments, it is to be understood that the invention is not limited to the disclosed embodiments, but, on the contrary, is intended to cover various modifications and equivalent arrangements included within the spirit and scope of the appended claims, and equivalents thereof.

[0059] <Description of some symbols>

first pixel **100**, second pixels **200**, third pixels **300**

What is claimed is:

1. A pixel arrangement structure of an organic light emitting diode display, comprising:

a first pixel having a center coinciding with a center of a virtual square;

- a second pixel separated from the first pixel and having a center at a first vertex of the virtual square; and a third pixel separated from the first pixel and the second pixel, and having a center at a second vertex neighboring the first vertex of the virtual square, wherein the first pixel, the second pixel, and the third pixel have polygonal shapes.
2. The pixel arrangement structure of claim 1, wherein the second pixel comprises a pair of second pixels, and the second pixels are separated from each other by the first pixel.
  3. The pixel arrangement structure of claim 1, wherein the third pixel comprises a pair of third pixels, and the third pixels are separated from each other by the first pixel.
  4. The pixel arrangement structure of claim 1, wherein the second pixel comprises a pair of second pixels, the third pixel comprises a pair of third pixels, and the second pixels and the third pixels enclose the first pixel in the virtual square.
  5. The pixel arrangement structure of claim 4, wherein each of the second pixels and the third pixels is larger in area than the first pixel.
  6. The pixel arrangement structure of claim 5, wherein the first pixel has an octagonal shape, and at least one of the second pixel or the third pixel has an octagonal shape.
  7. The pixel arrangement structure of claim 5, wherein the first pixel has an octagonal shape, and one of the second pixel or the third pixel has a hexagonal shape and an other of the second pixel or the third pixel has a quadrilateral shape.
  8. The pixel arrangement structure of claim 7, wherein the virtual square comprises a pair of virtual squares sharing a common side, the first pixel comprises a pair of first pixels having centers respectively coinciding with centers of the virtual squares, and the first pixels have octagonal shapes that are symmetrical to each other.
  9. The pixel arrangement structure of claim 7, wherein each of the second pixels is larger in area than each of the third pixels.
  10. The pixel arrangement structure of claim 9, wherein a distance between the first pixel and the second pixels as well as a distance between the first pixel and the third pixels is a same first length.
  11. The pixel arrangement structure of claim 10, wherein the virtual square comprises a pair of virtual squares sharing a common side, the first pixel comprises a pair of first pixels having centers respectively coinciding with centers of the virtual squares, a distance between each of the second pixels and the third pixels is a same second length, and a distance between the first pixels is a third length that is longer than the first length and the second length.
  12. The pixel arrangement structure of claim 1, wherein the first pixel, the second pixel, and the third pixel are configured to emit different color light.
  13. The pixel arrangement structure of claim 12, wherein the first pixel is configured to emit green light, one of the second pixel or the third pixel is configured to emit blue light, and an other of the second pixel or the third pixel is configured to emit red light.
- \* \* \* \* \*

专利名称(译)	用于有机发光二极管显示器的像素排列结构		
公开(公告)号	<a href="#">US20140071030A1</a>	公开(公告)日	2014-03-13
申请号	US13/872018	申请日	2013-04-26
[标]申请(专利权)人(译)	三星显示有限公司		
申请(专利权)人(译)	三星DISPLAY CO. , LTD.		
当前申请(专利权)人(译)	三星DISPLAY CO. , LTD.		
[标]发明人	LEE SANG SHIN		
发明人	LEE, SANG-SHIN		
IPC分类号	G09G3/32		
CPC分类号	G09G3/3208 H01L27/3216 H01L27/3218		
优先权	1020120022967 2012-03-06 KR 1020130044993 2013-04-23 KR		
外部链接	<a href="#">Espacenet</a> <a href="#">USPTO</a>		

摘要(译)

提供了一种有机发光二极管 ( OLED ) 显示器的像素排列结构。像素排列结构包括：第一像素，其中心与虚拟正方形的中心重合；第二像素与第一像素分离并且具有位于虚拟正方形的第一顶点的中心；第三像素与第一像素和第二像素分离，并且具有与虚拟正方形的第一顶点相邻的第二顶点的中心。第一像素，第二像素和第三像素具有多边形形状。

